

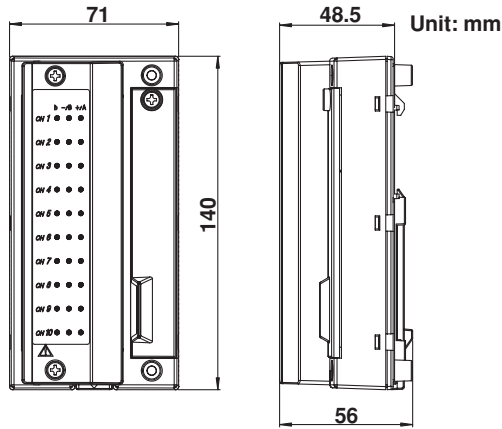

# User's Manual

# MX100/MW100 Handling of the 10-CH Screw Terminal Block (772061)

## External Dimensions



If not specified, the tolerance is  $\pm 3\%$ .

## Names of Sections and Terminal Arrangement

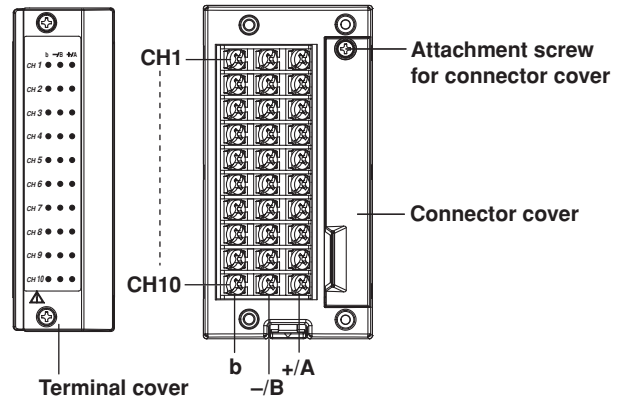

## Connecting to the Input Module

Remove the terminal plate of the 10-CH, Medium-Speed Universal Input Module, 10-CH, Pulse Input Module, and the 10-CH, High-Speed Digital Input Module. Then, use the connection cable between the input module and screw terminal block (sold separately) to connect the input module and the 10-CH screw terminal block as shown in the figure below.

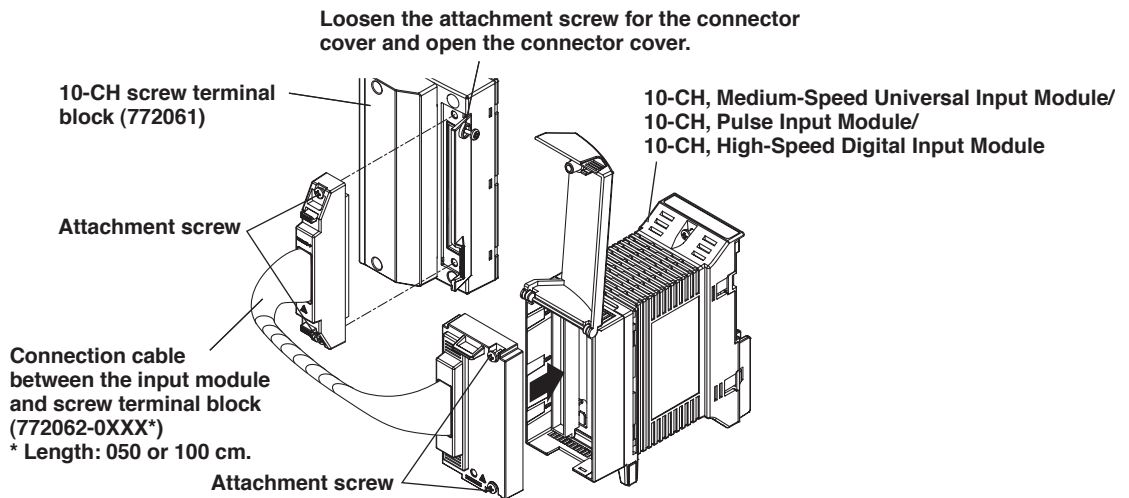

### Note

The 10-CH, Pulse Input Module is compatible with the MW100.

## Attachment to a DIN Rail

The screw terminal block can be attached to a DIN rail as shown in the figure below.

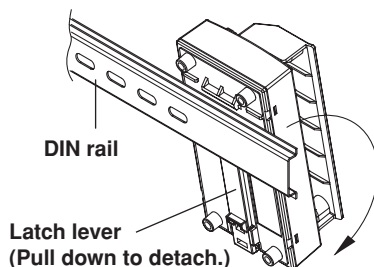

---

## General Precautions When Wiring the Input Signal Wires

---



### WARNING

- To prevent the possibility of electric shock when wiring, confirm that the power supply source and signal source are turned OFF. After making the connections, secure the terminal cover and do not touch the terminals with your hands.
- For signal wires on which voltage exceeding 30 VAC/60 VDC is applied relative to the ground potential or between signals, use double (reinforced) insulation wires. For all other signal wires, use basic insulation wires. For the withstand voltage of insulation wires, see the table below.

Applied Voltage (Vrms or VDC)	Basic Insulation	Double (reinforced) Insulation
30 (60 VDC) to 100	620 Vrms	1000 Vrms
101 to 150	840 Vrms	1400 Vrms
151 to 300	1390 Vrms	2300 Vrms
301 to 600	2210 Vrms	3700 Vrms

- When wiring the screw terminal block, attach the screw terminal block to the input modules before inputting signals. Electric shock or fire can result if signals are applied to the terminals when the screw terminal block is not connected to the input modules.
- When wiring to the screw terminal block, use round, insulation coated crimp-on lugs (for 4-mm screws) on the terminals that do not come out when loose.
- To prevent fire, use signal wires with a 75°C or higher temperature rating.



### CAUTION

- If a large pulling force is applied to the input signal wires connected to the MX100 and MW100, the terminal or signal wire may break. To prevent this from happening, secure all the wiring cables to the installation panel.
- Do not apply a voltage exceeding the value indicated below to the input terminals of the 10-CH, Medium-Speed Universal Input module. Doing so can damage the module.
  - Maximum input voltage  
Voltage range of 1 VDC or less, TC, RTD, and DI (contact):  $\pm 10$  VDC  
Voltage range of 2 VDC or more, and DI (LEVEL):  $\pm 120$  VDC
  - Maximum common mode voltage  
Between channels: 120 VACrms (50/60 Hz)  
Input to ground: 600 VACrms (50/60 Hz)
- Do not apply a voltage exceeding the value indicated below to the input terminals of the 10-CH, Pulse Input module and 10-CH, High-Speed Digital Input modules. Doing so can damage the modules.
  - Maximum input voltage  
10-CH, Pulse Input module and 10-CH, High-Speed Digital Input module:  
 $\pm 10$  VDC (Pulse input and digital input (-D05)),  $\pm 50$  VDC (digital input (-D24))
  - Maximum common mode voltage  
Input to ground: 250 VACrms (50/60 Hz)
- When using the pulse input module with contact input, the measured signal becomes easily affected by wiring impedance at high speed. The cable should be approximately 25 m or less when the pulse width is 0.05 ms, or 500 m or less at 0.5 ms. The wiring impedance varies depending on the such things as the cable length, type, and wiring conditions.
- The MX100 and MW100 are a measurement category II (IEC61010-1) and overvoltage category II (CSA1N.61010-1) instrument.

---

## Wiring Procedure, Specifications, and Other Items Related to the Input/Output Modules

See the MX100/MW100 Data Acquisition Unit Installation and Connection Guide (IM MX100-72E) provided with the main module, or the MX100 Data Acquisition Unit User's Manual (IM MX100-01E) or the MW100 Data Acquisition Unit User's Manual (IM MW100-01E) contained in the manual CD-ROM.